

**DIMENSIONS & WEIGHT FOR BOTH CARS**

<b>Overall Length</b>	412"	(10.47 m)
<b>Overall Width</b>	100"	(2.54 m) without mirrors
<b>Overall Height</b>	108"	(2.74 m)
<b>Ground Clearance</b>	22"	(55.9 cm)
<b>Curb Weight</b>	30,000 lbs	(13,608 kg) without options
<b>Payload</b>	25,000 lbs	(11,340 kg) combined
<b>GVWR</b>	55,000 lbs	(24,948 kg)

**DIMENSIONS & WEIGHT FOR FRONT CAR**

<b>Overall Length</b>	189"	(4.80 m)
<b>Overall Width</b>	100"	(2.54 m) without mirrors
<b>Overall Height</b>	108"	(2.74 m)
<b>Deck Area &amp; Dimensions</b>	54 ft <sup>2</sup> (101" x 76")	5.02 m <sup>2</sup> (2.56m x 1.93m)
<b>Ground Clearance</b>	22"	(55.9 cm)
<b>Curb Weight</b>	20,000 lbs	(9,072 kg)
<b>Payload</b>	5,000 lbs	(2,268 kg) with 4 man cab
<b>GVWR</b>	25,000 lbs	(11,340 kg)

**DIMENSIONS & WEIGHT FOR REAR CAR**

<b>Overall Length</b>	170"	(4.31 m)
<b>Overall Width</b>	97"	(2.46 m)
<b>Deck Height</b>	43"	(109.2 cm)
<b>Deck Area &amp; Dimensions</b>	120 ft <sup>2</sup> (100" x 170")	11.15 m <sup>2</sup> (2.54 m x 4.32 m)
<b>Frame Height</b>	39"	(99.1 cm)
<b>Ground Clearance</b>	22"	(50.8 cm)
<b>Curb Weight</b>	10,000 lbs	(4,535 kg) without flatbed deck or dump box
<b>Payload</b>	20,000 lbs	(9,072 kg) without flatbed deck or dump box
<b>GVWR</b>	30,000 lbs	(13,607 kg)

**PERFORMANCE**

<b>Maximum Speed</b>	20 mph	(32.2 km/h)
<b>Ground Pressure</b>	at 6" penetration	
Unloaded	2.8 PSI	(19.3 kPa)
Loaded to the max	5.1 PSI	(35.16 kPa)
<b>Maximum Gradeability</b> (static test with maximum load)		
Up Hill	35°	(70%)
Side Hill	20°	(36%)
<b>Turning Radius</b>	21' to centerline, (17' with steering assist)	
<b>Fording Depth</b>	57"	

**FRONT CAR (Standard Equipment)**

- 4-man closed cab with Roll Over Protection Structure
- L/R windshield wipers & washers
- Recirculation fan, air conditioning and heater/defroster
- Driver's air suspension seat with 3-point seatbelt
- 3x passenger spring suspension seats with 2-point seatbelts
- Dual escape hatches
- Dual side entrance steps
- Side opening windows
- Dual exterior mirrors
- Rear view camera
- Center console with storage
- High/low beam front LED Lights
- Full DOT road lighting (position, turn, stop, tail)
- AM/FM radio with two speakers
- Dual USB power outlets
- 1 dome light
- In-cab touch screen display for vehicle status & statistics
- Tilt steering wheel
- F/N/R selector
- Dual circuit hydraulic wet brakes with accumulator reserves (regenerative braking above 3 mph)
- 120v block heater
- 12vdc heated fuel filler
- 2 S.A.H.R. (Spring Applied Hydraulic Release) parking brakes in each axle
- Manual parking brake release
- Rear deck
- Rear mudflaps
- Deck access steps

**REAR CAR (Standard Equipment)**

- Frame only with pin-on brackets and shipping cover
- Pintle hook receiver
- Stop/tail/turn lights

**ENGINE & DRIVE TRAIN**

<b>Make</b>	Cummins
<b>Model</b>	QSB 6.7 Tier 4 Final
<b>Type</b>	Turbocharged diesel
<b>Displacement</b>	6.7 L (408.86 cu. in.)
<b>Injection System</b>	Direct
<b>Peak Power</b>	250 HP (186.5 kW) at 2,000 rpm
<b>Torque</b>	850 lb-ft (1,150 N-m) at 1,500 rpm
<b>Battery Type</b>	LTO (Lithium Titanate Oxide)
<b>Traction Battery Pack</b>	24 kWh / 650v
<b>Generator / Drive Motors</b>	3
<b>Peak Power &amp; Torque per Motor</b>	254 HP (190 kW) & 1,735 lb-ft (2,360 N-m)

## FRAME, SUSPENSION, WHEELS

<b>Frame</b>	Corten, welded tub
<b>Suspension</b>	Sprung walking beam with dual articulating bogie wheels
<b>Wheels</b>	16 front car + 16 rear car = 32 wheels (each wheel is double, 64 wheels total)
<b>Size</b>	12" steel with oil hub

## TRACKS

<b>Tracks</b>	One-piece 24" (600 mm) rubber track with steel reinforcements
---------------	---

## STANDARD HYDRAULIC SYSTEM

- Semi-synthetic hydraulic oil
- Return filter with in-cab service indicator
- Low level warning
- Low level shutdown
- High temperature warning
- Hydraulically damped center link with articulation control

## FLUID CAPACITIES

	<b>LITRES</b>	<b>U.S. GALLONS</b>
<b>Cooling System</b>	15.2	4.0
<b>Auxilliary Hydraulic Oil Tank</b>	68	18.0
<b>Fuel Tank</b>	300	80.0
<b>DEF Tank</b>	10	2.6

## ELECTRICAL

<b>Voltage</b>	12v
<b>Battery Capacity at 0° F</b>	2 x 1,060 CCA
<b>Alternator Capacity</b>	120 Amps
<b>Ground</b>	Negative

## STANDARD EQUIPMENT

<b>Air Cleaner - Type</b>	Dry – two stages with air filter restriction gauge
<b>HMI &amp; Controls</b>	Low service brake pressure warning Speedometer Fuel gauge Engine hour meter Battery status indicator (state of charge and charge/discharge rate) Low oil pressure warning / shutdown Low engine coolant level warning High engine coolant temperature warning Low traction coolant level warning High traction coolant level warning Air filter service warning Hydraulic oil filter service warning
<b>Manuals</b>	2x “Operations”, 2x “Parts & Service”

## FRONT CAR & CAB OPTIONS

- Front bumper
- Medium duty front plow
- Front hydraulic winch (20,000 lbs)
- Front brush guard
- ROPS cab certification
- Intermittent windshield wipers
- Passenger seats air suspension
- Passenger seats 3-point seatbelts
- Dual sun visors
- Dual side mirrors, heated
- Dual side mirrors, power adjust, heated
- Premium cab sound and heat insulation
- GPS
- Radio with speakers
- Pressurized cab
- Escape hatch with adjustable angle
- Tinted glass
- Jib boom crane
- Outriggers for crane
- 150 gal diesel fuel tank with 12v hand pump 15 gpm
- Bulk liquid tank
- Stake side rear deck
- Auxiliary power inverter – 3 phase 20 kW for welding with 110v and 220v plug-ins
- Auxiliary power inverter – 3 phase / 60 hz / 600v / 60 kW output depending on conditions

## ENGINE & COLD WEATHER OPTIONS

- 12v engine coolant heater (42,000 BTU with 7 day timer)
- Synthetic engine oil
- 2x 120v battery heaters

## LIGHTING OPTIONS

- Amber beacon
- Front 86w LED light bar
- Dual 80w LED work lights
- Remote control spotlight

## REAR CAR OPTIONS

- Flatbed deck with access ladder
- Stake side flatbed deck
- Removable wood sides for flatbed deck
- Flatbed deck, droppable
- Dump box (rock box) 8 yd<sup>3</sup> (6 m<sup>3</sup>) 11,000 lbs (5,000 kg) max capacity
- Personnel carrier, droppable, self contained (12x fold up seats, 8x windows, 2x escape hatches, 1x rear door, diesel heating and battery powered air conditioning
- Personnel carrier premium insulation for operations to -40 deg C / -40 deg F
- Auxiliary hydraulic system (up to 25 gpm at 3,000 psi)
- Hose reel with hydraulic tools outlet
- DC auxiliary power outlet
- Deck crane
- Outrigger & subframe for crane
- Tank for liquid transport
- Hook loader
- Rear hydraulic winch (20,000 lbs)
- Pintle hook
- Pintle hook with trailer wiring (14,000 lbs towing capacity)

## MISCELLANEOUS OPTIONS

- Maintenance kit
- Recommended spare parts for remote operations
- Other options available upon request

### Voyager 12T Four Track Articulated Carrier - Performance

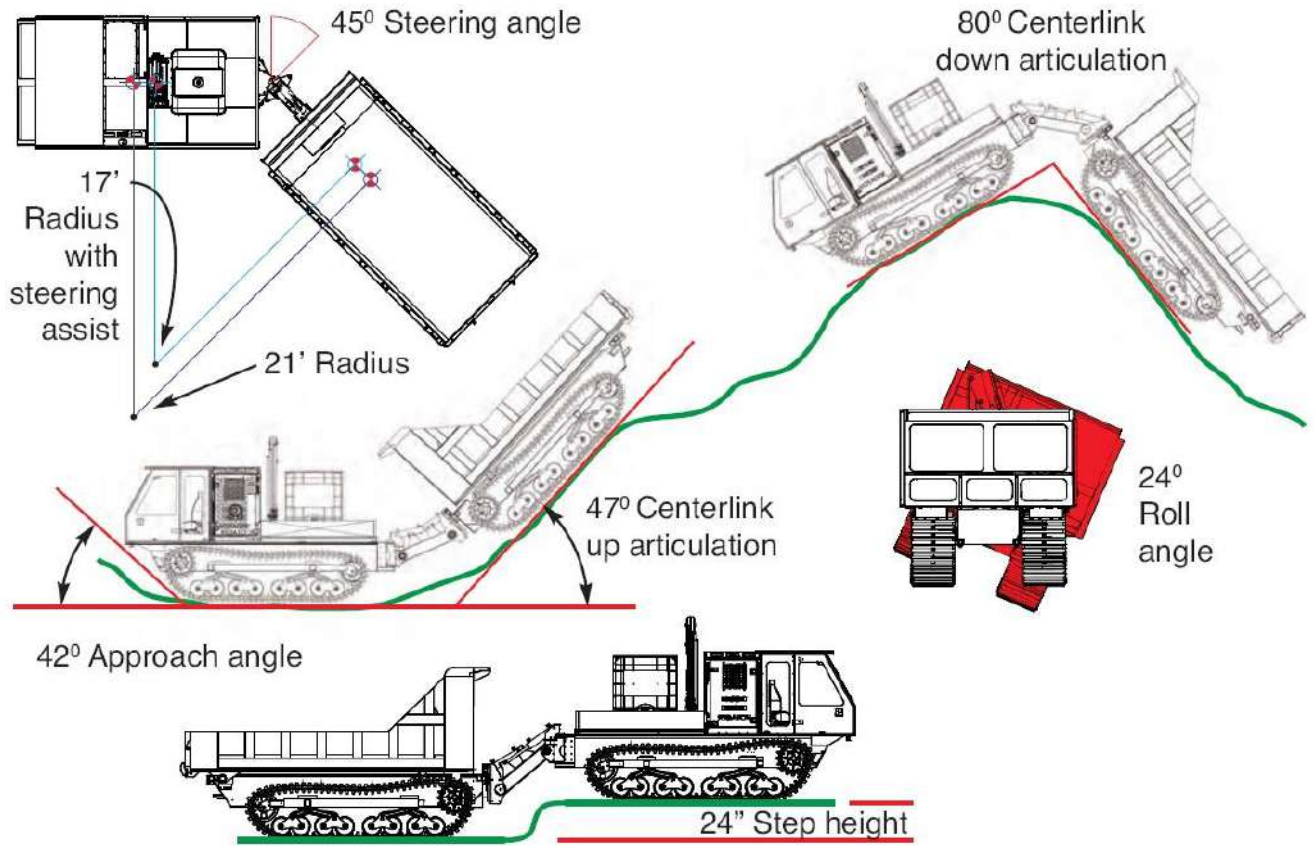

### Voyager 12T Four Track Articulated Carrier - Dimensions

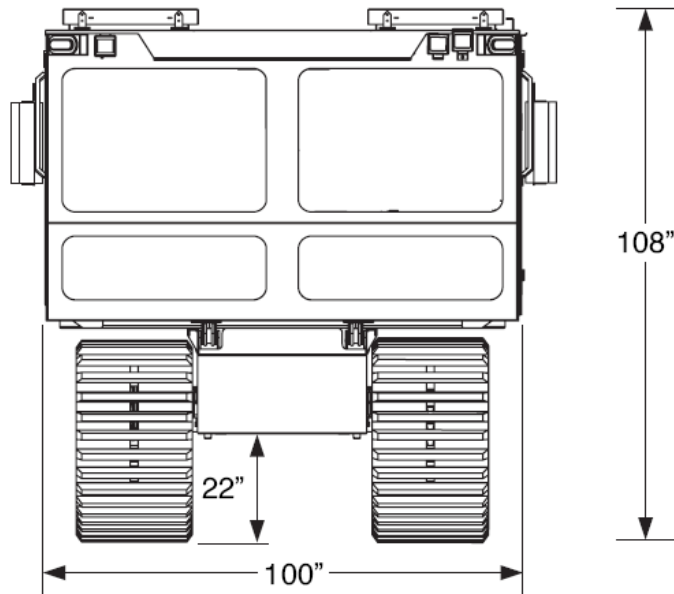

### Voyager 12T Four Track Articulated Carrier - Dimensions

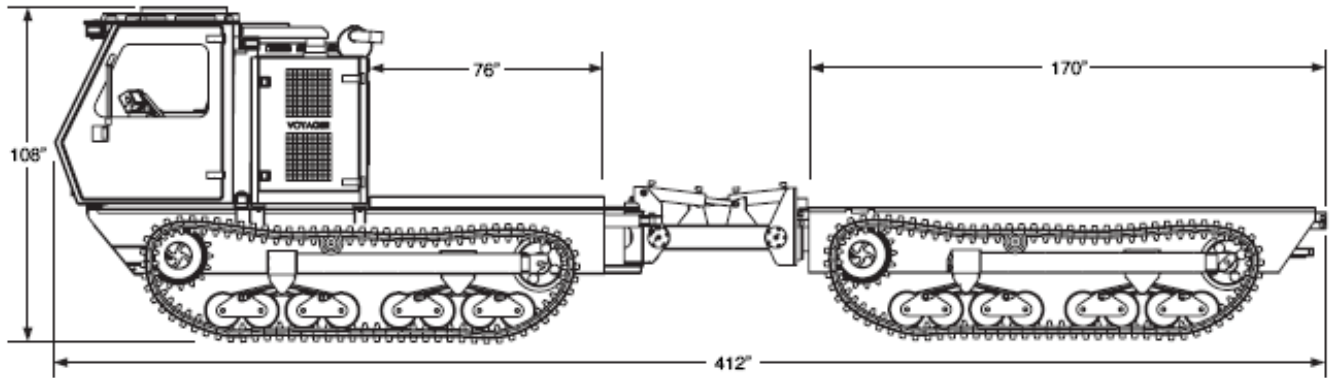



### Voyager 12T Four Track Articulated Carrier - Dimensions

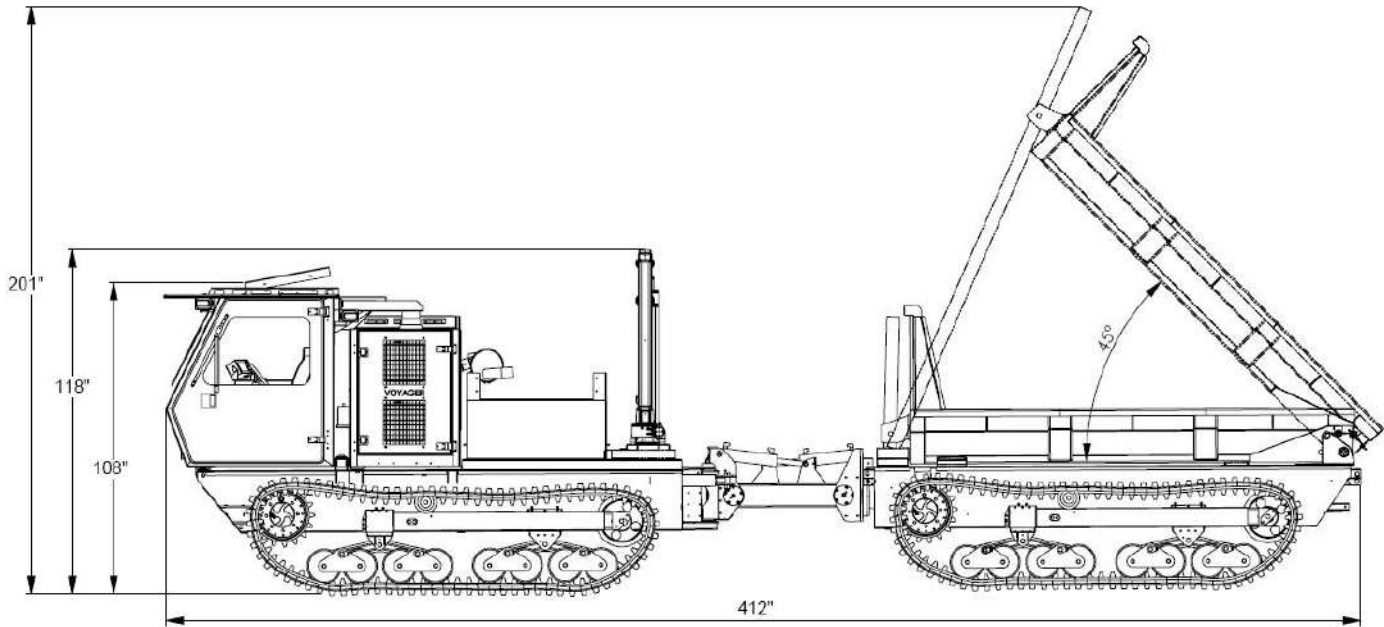

### Optional Voyager 12T 12-Man Cab Rear Car (droppable)

Comes with: 12x fold up seats, 8x windows, 2x escape hatches, 1x rear door, diesel fired heating, battery power air conditioning , auxiliary diesel fuel tank, premium insulation for operations to -40 deg C / -40 deg F.

